

## NICHE EVOLUTION AND ADAPTIVE RADIATION: TESTING THE ORDER OF TRAIT DIVERGENCE

D. D. ACKERLY,<sup>1,4</sup> D. W. SCHWILK,<sup>2</sup> AND C. O. WEBB<sup>3,5</sup>

<sup>1</sup>Department of Integrative Biology, University of California, Berkeley, California 94720 USA

<sup>2</sup>U.S. Geological Survey/WERC, Sequoia and Kings Canyon Field Station, Three Rivers, California 93271 USA

<sup>3</sup>Department of Ecology and Evolution, Yale University, New Haven, Connecticut 06511 USA

**Abstract.** In the course of an adaptive radiation, the evolution of niche parameters is of particular interest for understanding modes of speciation and the consequences for coexistence of related species within communities. We pose a general question: In the course of an evolutionary radiation, do traits related to within-community niche differences ( $\alpha$  niche) evolve before or after differentiation of macrohabitat affinity or climatic tolerances ( $\beta$  niche)? Here we introduce a new test to address this question, based on a modification of the method of independent contrasts. The divergence order test (DOT) is based on the average age of the nodes on a tree, weighted by the absolute magnitude of the contrast at each node for a particular trait. The comparison of these weighted averages reveals whether large divergences for one trait have occurred earlier or later in the course of diversification, relative to a second trait; significance is determined by bootstrapping from maximum-likelihood ancestral state reconstructions. The method is applied to the evolution of *Ceanothus*, a woody plant group in California, in which co-occurring species exhibit significant differences in a key leaf trait (specific leaf area) associated with contrasting physiological and life history strategies. Co-occurring species differ more for this trait than expected under a null model of community assembly. This  $\alpha$  niche difference evolved early in the divergence of two major subclades within *Ceanothus*, whereas climatic distributions ( $\beta$  niche traits) diversified later within each of the subclades. However, rapid evolution of climate parameters makes inferences of early divergence events highly uncertain, and differentiation of the  $\beta$  niche might have taken place throughout the evolution of the group, without leaving a clear phylogenetic signal. Similar patterns observed in several plant and animal groups suggest that early divergence of  $\alpha$  niche traits might be a common feature of niche evolution in many adaptive radiations.

**Key words:** adaptive radiation; *Ceanothus*; Cerastes; Coast Range; community assembly; *Euceanothus*; habitat; niche conservatism; phylogenetic comparative methods; specific leaf area; Sierra Nevada; trait divergence; Transverse Range.

### INTRODUCTION

Ecologists have long considered niche differences among species to be essential for species coexistence (Chesson 2000, Chase and Leibold 2003; but see Hubbell [2001]). The evolution of niche differences among closely related species has received particular attention. Because close relatives tend to be ecologically similar in many respects (Darwin 1859, Felsenstein 1985, Harvey and Pagel 1991, Webb et al. 2002), those features that do diverge during speciation will provide important insights into ecological differentiation and consequences for coexistence of closely related species. It is useful in this context to distinguish two scales of niche differentiation, corresponding to different scales

of species distributions. At large spatial scales, species can occupy different macrohabitats or climatic envelopes; the resulting distributions will be largely allopatric, or, if they do overlap geographically, individuals of the two species would rarely encounter one another due to habitat differentiation. At smaller scales, related species that co-occur in local communities usually exhibit spatial or temporal differentiation in microhabitat, resource use, diet, or other factors. It is at this local scale, where the balance of intra- and interspecific interactions influences coexistence and community structure, that the niche concept has played the most important role. Following Pickett and Bazzaz (1978) and Silvertown et al. (2006), we employ the term  $\alpha$  niche to describe these small-scale components of the niche that differ among co-occurring species, corresponding to Whittaker's (1975) use of  $\alpha$  diversity for diversity of local communities. In contrast, the  $\beta$  niche is defined as macrohabitat and climate factors related to larger scale distributions, corresponding to the  $\beta$  component of diversity among habitats in a landscape. In this paper, we do not distinguish the proposed  $\beta$  and  $\gamma$  niche, which

Manuscript received 21 January 2005; revised 9 August 2005; accepted 11 August 2005. Corresponding Editor: A. A. Agrawal. For reprints of this Special Issue, see footnote 1, p. S1.

<sup>4</sup> E-mail: dackerly@berkeley.edu

<sup>5</sup> Present affiliation: Arnold Arboretum of Harvard University.

refers to distributions at the scale of habitat vs. geographic range (Silvertown et al. 2006), as these have equivalent implications in terms of species interactions at the community level.

It has been argued that species within local communities tend to be phylogenetically overdispersed; i.e., closely related species co-occur less than expected, relative to an appropriate null model (Elton 1946, Williams 1964, Gotelli and Graves 1996, Cavender-Bares et al. 2004). This pattern would suggest that  $\alpha$  niche parameters are evolutionarily conserved and/or  $\beta$  niche parameters are highly divergent, such that close relatives tend to occupy different macrohabitats and hence different communities (Elton 1946, Williams 1964, Gotelli and Graves 1996, Cavender-Bares et al. 2004). The alternative, if  $\alpha$  niche traits were more labile, would facilitate coexistence and divergent resource use in sibling species within local communities. Divergence of macrohabitat parameters among sibling taxa is compatible with the allopatric model of speciation, as disjunct populations in a heterogeneous landscape are likely to encounter distinct habitats (Graham et al. 2004; but see Wiens [2004]). Differentiation of the  $\alpha$  niche would then represent a later stage of evolutionary divergence, either resulting from or directly promoting species coexistence as the ranges of the now distinct species expand into each other's territory.

In an important paper, Diamond (1986) argued for this "habitat-first" model of speciation, based on his observations that closely related bird species in New Guinea tend to be allopatric and occupy distinct macrohabitats along elevational or climatic gradients (see review by Schluter [2000]). In addition, Diamond and Schluter both argued that the habitat-first speciation model can be extended to the analysis of adaptive radiations, based on a parsimonious assumption that rates of evolution do not dramatically change. In other words, if habitat divergence represents the first stage of speciation among close relatives, then it would also be characteristic of early speciation events at the base of an adaptive radiation. As a corollary, if differentiation of  $\alpha$  niche occurs late in speciation, or is observed among distant relatives, then it would be characteristic of the later stage of adaptive radiation. Streebman and Danley (2003) presented a related model, arguing that vertebrate adaptive radiations follow a trajectory of divergence along three axes: habitat, trophic morphology, and communication, usually in that order. However, their use of "habitat" refers more to microhabitats within a community (e.g., benthic vs. limnetic sticklebacks), rather than Diamond's larger scale differentiation among elevational bands and different forest types occupied by New Guinea birds. This ambiguity over the use of the word habitat is unfortunate, as there is a substantive difference between these models in their emphasis on large-scale habitat differences, implying allopatric populations, vs. microhabitat differentiation within local communities.

Recent developments of phylogenetic methodology offer outstanding opportunities to reevaluate these classic questions. Here, we present a comparative approach to the problem of niche evolution by introducing a new comparative method designed to test the relative timing of divergence in two ecological traits (e.g.,  $\alpha$  vs.  $\beta$  niche axes); we then use the test to evaluate the sequence of trait divergence in the radiation of the woody plant group *Ceanothus* in California. Our results indicate that  $\alpha$  niche traits related to local scale coexistence diverge first in the radiation of this group, a pattern that is shared with several other plant and animal radiations.

#### DIVERGENCE ORDER TEST

The divergence order test (DOT) was designed to address these questions of niche evolution, as well as other questions regarding the relative sequence of diversification events in a clade. The test examines the relative timing of evolutionary divergence for two continuous characters, and it is based on a modification of the method of phylogenetic independent contrasts (Felsenstein 1985). Independent contrasts transform the trait data for  $N$  species into a set of  $N - 1$  contrasts, each based on the difference between trait values across a phylogenetic divergence. Under the assumption that the trait evolved independently at each divergence, the contrasts provide a robust basis on which to test hypotheses of correlated evolution, addressing the underlying historical pattern of trait evolution as well as better meeting the assumptions of standard parametric statistics (Garland et al. 1992). For the DOT, we modify this method and use the absolute differences between related nodes derived from maximum-likelihood estimates of ancestral trait reconstructions, obtained using ANCML (Schluter et al. 1997). This approach allows us to incorporate the uncertainty of reconstructions in deeper nodes.

The divergence order test is based on two sets of numbers: (1) the absolute value of the unstandardized contrasts for trait  $i$  across the nodes ( $k = 1, 2, \dots, N$ ) of a phylogeny ( $C_{ik}$ ), which measures the magnitude of the divergence that occurred at each node regardless of the direction of change; and (2) the age of each node ( $A_k$ ). We then calculate a weighted mean age of divergence for each trait as follows:

$$W_i = \frac{\sum_{k=1}^N A_k C_{ik}}{\sum_{k=1}^N C_{ik}}. \quad (1)$$

The result is an average age, in units of time, that indicates whether the large divergences in a trait tended to occur early or late in the diversification of a group (Fig. 1). Note that this age will not generally correspond to the age of any single divergence; it is simply a statistical measure of the tendency toward early or late

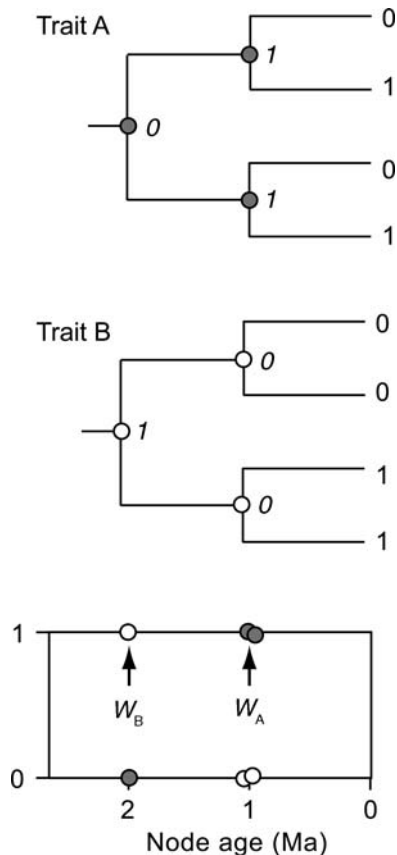

FIG. 1. Example of the divergence order test (DOT). Two patterns of trait divergence are illustrated on a simple phylogeny. Numbers at the tips of the phylogeny indicate two possible trait states, 0 or 1. Numbers at interior nodes (in italics) show the contrast for that node. Trait A (open circles) exhibits a pattern of late divergence, whereas Trait B (shaded circles) exhibits a pattern of early divergence. The lower panel plots contrast magnitude vs. age and shows the calculated weighted divergence age for Trait A ( $W_A = 1$  Ma [i.e., 1 million years ago]) and Trait B ( $W_B = 2$  Ma).

divergence for the trait in question. The DOT is then based on the comparison of the weighted divergence age for two traits ( $D = W_i - W_j$ ) to determine whether one trait diverged significantly earlier than the other, on average.

The DOT statistic is derived from contrasts between ancestral states and does depend on the accuracy of the ancestral estimates themselves (Oakley and Cunningham 2000). We do not consider the traits of outgroups in calculating ancestral states, as these are only necessary to identify trends in trait evolution within a group, and not the magnitude of divergences. The maximum-likelihood algorithm of ANCML assumes that the pattern of trait evolution fits a model of Brownian motion. Global squared-change parsimony, which is also based on Brownian motion, provides the same ancestral estimates, but no confidence limits. The fit to Brownian motion can be tested in several ways. First, using Felsenstein's (1985) algorithm, the correlation of

the absolute value of standardized independent contrasts and the standard deviation of those contrasts (the square root of subtending branch lengths) should be non-significant (Garland et al. 1992). A negative correlation would indicate larger contrasts than expected on rapid bifurcations, and vice versa for a positive correlation. The absolute values of standardized contrasts should also fit a half-normal distribution, and this can be checked visually using truncated normal probability plots. In addition, if several distinct clades are present (as in the *Ceanothus* case), homogeneity of evolutionary rates can be tested using a nonparametric comparison of standardized contrasts between groups (Garland 1992), or a recently introduced maximum-likelihood approach (O'Meara et al. 2005). In general, methods based on independent contrasts are fairly robust to violations of Brownian motion (Diaz-Uriarte and Garland 1996, Ackerly 2000), but this has not been evaluated for the calculation of standard errors by ANCML or the DOT analysis.

It can be useful to examine correlations between the two traits under consideration, though DOT does not require that the traits exhibit any particular pattern of correlated or independent evolutionary change. If changes in the two traits are tightly linked, then DOT will certainly not be significant, as the contrasts will be similar in magnitude at each node. However, differences in the magnitude of a few basal or distal nodes could result in a significant DOT outcome, and trait evolution could still be correlated overall on the tree.

We have explored several approaches to significance testing of the  $D$  statistic (see Appendix A). We present here our preferred method, based on a bootstrapping approach, to obtain confidence intervals for the two estimates of  $W$  and their difference,  $D$ . The rationale for this approach is that comparative methods, particularly independent contrasts, tend to underestimate the magnitude of older divergences for rapidly evolving traits. As a simple example, consider a bifurcating tree with four species at the tips. If each pair of sister taxa has divergent trait values, reflecting rapid trait evolution, then the averages for their respective common ancestors could be virtually identical and the basal contrast will be nearly or exactly zero (e.g., Fig. 1, Trait A). However, given the rapid rate of evolution for this trait, it is also possible that a large divergence occurred at the first node, followed by reversals at the subsequent nodes resulting in convergence among extant taxa. Maximum-likelihood estimates of ancestral states allow for this possibility by placing confidence limits on the ancestors (Schluter et al. 1997). If a trait evolves rapidly, then the confidence limits at deeper nodes will be large (see Appendix A, Fig. A1).

We use ANCML (Schluter et al. 1997) to generate maximum-likelihood estimates and confidence limits of ancestral states at each node; we then create bootstrap distributions of the potential magnitude of each divergence event (see Appendix A, Fig. A1). Hypo-

thetical ancestral values are sampled from the distribution for each trait at each node, and from each sample we calculate the corresponding values of  $C_{ik}$ ,  $C_{jk}$ ,  $W_i$ ,  $W_j$ , and  $D$ . We then examine the distribution of  $D$  values to determine whether  $D = 0$  falls outside the 95% confidence limits on the mean, indicating significance of the observed values at  $P \leq 0.05$ . The calculation and significance of the DOT method were implemented on Mac OS X, using awk scripts, R (R-project 2004), and ANCMML (see Supplement).

#### *Branch lengths and node ages*

As the objective of this test is to calculate relative timing of divergence events, the analysis should ideally be conducted with ultrametric, calibrated phylogenies based on a molecular clock, or rate-smoothed branches if the branch lengths violate a molecular clock (Sanderson 2002). Methods for obtaining relative ages are improving, although there can still be considerable uncertainty due to heterogeneous rates of molecular evolution and difficulty in establishing calibration points across different clades (Sanderson 2002, 2003). The DOT method will be robust to much of this uncertainty, because the same ages are used in the calculation of weighted divergence times for both traits. For the nodes along any contiguous path from the root to the tips, ages will always be correctly ordered, even if the actual values are uncertain. Problems would most likely arise if incorrect calibrations were applied to two or more independent segments of the tree (i.e., along different root-to-tip paths) in which different traits exhibited large evolutionary divergences. Attention to this problem is warranted in applications of the test.

#### CASE STUDY: COMMUNITY ASSEMBLY AND NICHE EVOLUTION IN *CEANOOTHUS*

The woody plant group *Ceanothus* comprises ~55 minimum-rank taxa (species or subspecies) that have primarily diversified within the California Floristic Province (McMinn 1942, Hardig et al. 2000). The group is divided into two well-supported clades (Jeong et al. 1997, Hardig et al. 2000) that differ consistently in several morphological and physiological traits related to drought tolerance. The two groups are considered subgenera, and are currently designated *Cerastes* and *Ceanothus*; for greater clarity (and consistency with phylogenetic naming conventions), we prefer the older name *Euceanothus* for the latter group. Species in *Cerastes* have thick leaves with stomatal crypts and have shallower roots and more embolism-resistant xylem than do members of *Euceanothus* (McMinn 1942, Hellmers et al. 1955, Davis et al. 1999). Additionally, species of *Cerastes* establish only from seed following fire, while *Euceanothus* species generally resprout as well (Wells 1969, Schwilk and Ackerly 2005). In a Mediterranean-type climate, seedlings of nonsprouting species must survive an intense summer drought period after winter or spring germination.

Despite these consistent differences in drought tolerance and fire response, both clades are widespread in the California Floristic Province, inhabiting chaparral, semiarid forests, and oak woodland. Often, species pairs representing one species from each of the subgroups co-occur, and it has been suggested that differences in fire response and/or tolerance of water stress facilitate this coexistence (Keeley 1977, Keeley and Zedler 1978, Davis et al. 1999). These patterns suggest that the basal divergence between the two clades involved  $\alpha$  niche traits related to drought tolerance or postfire regeneration strategies. In contrast, both clades are represented by species throughout California, suggesting more recent differentiation of the climatic niche envelope, representing the  $\beta$  niche (Knight and Ackerly 2001). Here we undertake four new analyses to quantify and test these observations. (1) We have assembled a co-occurrence data set from the literature, and we use null models to test for nonrandom patterns of co-occurrence between species from the two subgroups. (2) We combine the co-occurrence data with a trait data set to test whether co-occurring species differ significantly for traits related to plant growth strategies ( $\alpha$  niche) and are more similar than expected for traits related to climatic envelopes ( $\beta$  niche). (3) We reanalyze the *Ceanothus* phylogeny, based on internal transcribed spacer (ITS) sequence data, to obtain an ultrametric tree with branch lengths fit to a molecular clock. (4) We use this phylogeny and the trait data set to apply the DOT analysis, testing the prediction that  $\alpha$  niche traits diverged earlier than  $\beta$  niche traits in the evolution of *Ceanothus*.

#### METHODS

##### *Occurrence data*

A matrix of co-occurrence data for *Ceanothus* in California was obtained from a search of the literature and consultation with colleagues. A total of 51 sites were obtained that had two or more co-occurring *Ceanothus*, with a total of 16 different taxa (plots in the same location with the same species composition were recorded as one site; Nicholson 1993). Of these sites, 35, with 13 taxa, were located in chaparral of the Coast or Transverse ranges, while 16 sites with 7 taxa were from the Sierra Nevada region (CT and SN, respectively). Of the 51 sites, 48 had just two *Ceanothus* species, while the remainder had three. (See Appendix B for details of the occurrence data matrix.)

##### *Trait selection*

Although coexistence of *Ceanothus* species, in a matrix of other taxa in the community, can involve contrasting physiological or regeneration strategies, no direct studies of coexistence mechanisms in chaparral have been conducted. To reflect differences in drought tolerance, the ideal traits would be either a direct measure of xylem tolerance to embolism under water deficit or wood density, which is a close correlate of xylem tolerance (Hacke et al. 2001). These traits are known to vary

between the two subgroups (Davis et al. 1999), but they are not available for large numbers of species. As a proxy for contrasting physiological strategies, we used specific leaf area (SLA), the ratio of fresh leaf area to dry mass. This well-studied leaf functional trait plays an important role in the “leaf economic spectrum” of variation in plant metabolic rates (Wright et al. 2004). In general, species with higher SLA have shorter leaf life span and higher photosynthetic rates. In chaparral shrubs such as *Ceanothus*, high SLA is associated with less drought-tolerant leaves (Ackerly 2004b), and we have a large data set available for roughly two-thirds of the *Ceanothus* taxa (Ackerly 2004a). We do not claim that differences in SLA per se promote coexistence, but rather that they could be associated with suites of traits that are related to niche partitioning and differentiation in ecological strategies of co-occurring species. Data for SLA are species means collected previously from field, herbarium, and botanic garden specimens (Ackerly 2004a); three new taxa that appeared in the occurrence data set were added to this trait data set (*C. greggii*, *C. parvifolius*, and *C. sanguineus*) based on measurements of specimens in the University and Jepson Herbaria (University of California–Berkeley, California, USA). Values were log-transformed for all analyses, as relative differences are a better measure of physiological differentiation (Reich et al. 1997). (See Appendix C for details of the trait data set.)

At larger spatial scales ( $\beta$  niche), *Ceanothus* are differentially distributed with respect to edaphic conditions (e.g., serpentine specialists), habitat (chaparral vs. conifer forests), elevational range, and macroclimate (precipitation and temperature) (Hickman 1993, Nicholson 1993, Davis et al. 1999). We quantified the realized climatic niche, to characterize these large-scale distributions, by overlaying species distributions on climate maps of California and calculating mean climatic parameters for each species (Knight and Ackerly 2001). We have selected the mean precipitation and the mean January temperatures within the geographic range of each species, reflecting distributions along geographic and elevational gradients in California. The climate niche analysis serves as an indirect surrogate for unmeasured physiological traits related to species tolerances and distributions along climate gradients. This interpretation assumes that distributions do not simply reflect historical factors and limited dispersal potential. The contraction and expansion of chaparral during the interglacial periods (Graham 1999) argues against a strong role for dispersal limitation as a long-term constraint on species distributions.

#### Community assembly

We used five null models for community assembly to test several predictions, relative to patterns that would be expected by chance: (1) Species from the two clades (*Cerastes* and *Euceanothus*) co-occur more often than expected. (2) Values of SLA show greater variation among co-occurring species than expected. (3) Climate

niche parameters show greater similarity among co-occurring species than expected. The measure of trait dissimilarity within communities was simply the difference between species values for two-species samples, and the mean of the successive differences among ranked values in three-species samples. We also calculated the mean trait value for each community, which allowed us to test our additional null models. (4) The standard deviation of site means should be higher for climate niche parameters than expected by chance, due to turnover of species along climatic gradients. Finally, (5) among-site standard deviation in mean SLA should be lower than expected under the null, as the combinations of species from the two clades result in high trait disparity within sites and low disparity across sites. One-tailed tests were conducted for all hypotheses, based on these predictions, comparing the observed data to 999 randomizations.

As a null model, we use the “independent-swap” algorithm (Gotelli and Entsminger 2001), preserving both site diversity and species frequency of occurrence while randomizing assignments of species to sites. This is critical to ensure that patterns of trait assembly do not simply reflect differential abundance of particular species. All calculations were carried out in R (R-project 2004); the swap algorithm was implemented by S. Kembel in C as part of the PHYLOCOM package (Webb et al. 2004).

#### Phylogeny

The *Ceanothus* phylogeny of Hardig et al. (2000) was reanalyzed to obtain an ultrametric tree fit to a molecular clock for the taxon sample in our trait data set. Conflicting phylogenies for *Ceanothus* based on ITS vs. *matK* sequence data could reflect lineage sorting during rapid radiations or hybridization (Hardig et al. 2000), and ITS (which is a nuclear marker) was selected as a more reliable estimator of the “true” species tree. Limited sampling of *ndhF* (10 taxa; Jeong et al. 1997) is insufficient to incorporate in the broader analysis considered here. ITS sequence data for 76 accessions (73 *Ceanothus* and 3 outgroups [*Adolphia californica*, *Zizyphus obtusifolia*, and *Spyridium parvifolium*]) were obtained from GenBank (accessions GBAN-AF048901 through GBAN-AF048975; Hardig et al. 2000). Sequences were aligned with ClustalX using default parameters, and alignments were checked by eye (no manual adjustments were made); total aligned sequence length for ITS1, ITS2, and the intervening 15S region was 627 nucleotides. Taxa with identical sequences were kept in the analysis, for use later in comparative analyses. Multiple sequences for individual taxa were pruned to one representative sequence, based on preliminary analyses (Hardig et al. 2000). The resulting analysis included 56 *Ceanothus* sequences and 96 informative characters. Phylogenetic analysis was conducted with PAUP\*, using parsimony criteria and a heuristic search (random addition sequence with 10 replicates, TBR, MULTREES in effect, collapse zero-length branches in

effect, and steepest descent not in effect) (Swofford 2002). This analysis resulted in 174 equally parsimonious trees of length 322 on one island, which was hit in all 10 replicate searches. The strict consensus of the equally parsimonious trees was very similar to the results reported by Hardig et al. (2000). The most significant difference was that we obtained more resolution within *Euceanthus*, with the Western group (Hardig et al. 2000: Fig. 1) monophyletic and nested within a paraphyletic Eastern group.

For comparative analysis, ANCML (Schluter et al. 1997) requires fully bifurcating phylogenies. It is possible to generate these by randomly resolving the trees obtained in the analysis just described (in which zero-length branches were collapsed), but we are not aware of software that will provide alternative resolutions while maintaining branch lengths. As an alternative, we conducted a second parsimony search in PAUP\* with the same parameters, but with zero-length branches not collapsed and MAXTREES = 10 000. *Ceanothus oliganthus* ssp. *oliganthus*, which was present in our ecological data but missing from the molecular data, was added to the matrix with the same sequence as *C. oliganthus* ssp. *sorediatus*. Given taxa with identical sequences, this search quickly reached the maximum number of trees, with length = 322, as in the prior case. We then pruned the trees to include only the 39 taxa for which we had phenotypic data, resulting in 3254 unique topologies (outgroups were not considered in the analysis of ancestral states). For further analysis, 100 trees were selected from this set by sampling every 20th tree (because immediately adjacent trees tend to be similar to each other). This set of 100 alternative, fully bifurcating trees was used for all subsequent analyses.

#### Branch lengths

Maximum-likelihood methods were used to fit branch lengths to the 100 topologies, based on the HKY85 model with transition/transversion rates fit empirically from the data (Swofford 2002). A molecular clock was not rejected using this model ( $P > 0.05$  for all trees), so the branch lengths fit with a molecular clock were used for comparative analyses. Based on an independent analysis of rates of *rbcL* evolution in *Ceanothus* (Jeong et al. 1997), the split between *Cerastes* and *Euceanthus* was calibrated at 18–39 Ma. Fossil evidence provides independent confirmation of the minimum age, as taxa assignable to both clades appear in the fossil record by 18 Ma (Chaney 1927, Axelrod 1956). Using this calibration for the basal node, the clock-calibrated tree suggests that radiation of each of the two (*Cerastes* and *Euceanthus*) began no more recently than 4–5 Ma, at about the same time as the onset of the Mediterranean-type climate in California.

The inclusion of taxa with identical sequences (a common occurrence for rapidly speciating groups) results in zero-length branches in the phylogeny (i.e., a

polytomy). Zero-length branches create problems for both ANCML and independent contrasts, as they imply instantaneous evolutionary divergence (a hard polytomy), whereas they might reflect uncertainty of the sequence of speciation events (soft polytomy) as much as rapid radiation. Zero-length branches represent truncated estimates of elapsed time since speciation, since each branch will remain at zero length until the first fixed base change occurs. We addressed this problem by adjusting zero-length branches to a small nonzero value ( $1.0 \times 10^{-4}$ ) slightly lower than the shortest branches resulting from the maximum-likelihood fit to the molecular clock, which ranged from  $1.03 \times 10^{-4}$  to  $4.94 \times 10^{-4}$  across the 100 trees. Based on our calibration, this adjustment represents an absolute time of  $\sim 5 \times 10^4$  yr. Note that these small divergences (especially if they occur on both sides of a bifurcation) will lead to an inflated estimate of the Brownian motion rate parameter and, hence, broader confidence intervals on ancestral states. This will increase the standard errors of weighted divergence age ( $W$ ) from our bootstrap procedure, leading to a more conservative test of significance for the DOT statistic. We recognize that this is an imperfect solution and hope that the problem of zero-length branches will be addressed in future research on branch length calibration for comparative analysis.

#### Divergence order test analysis

We conducted the DOT analysis based on the average age of internal nodes, weighted by the absolute value of the unstandardized independent contrasts for each trait. Significance of the difference in ages was assessed by bootstrapping trait histories from the mean and standard deviations obtained from ANCML. Given the strong preliminary data that we have introduced, we conducted one-tailed tests of the hypothesis that SLA divergence occurred earlier than divergences in climate niche parameters.

## RESULTS

### Trait variation

Across the entire trait data set (39 taxa), specific leaf area (SLA) was significantly higher in *Euceanthus* than *Cerastes*. Precipitation and SLA were weakly correlated overall ( $R = 0.25$ ), and they were essentially independent based on independent contrasts ( $R = 0.04$ ) (Fig. 2A). January temperature and SLA were negatively correlated across species ( $R = -0.35$ ) and based on independent contrasts ( $R = -0.31$ ). This negative relationship was also apparent within *Euceanthus*, but not in *Cerastes* (Fig. 2B). The decline in *Euceanthus* reflects the transition from deciduous taxa occupying the coldest ranges (e.g., *C. parvifolius*) to evergreens at lower latitudes or elevations. The most striking aspect of both relationships is the marked difference in SLA between the clades that is maintained across the climatic gradients, consistent with the prediction of local co-occurrence between species that differ in SLA.

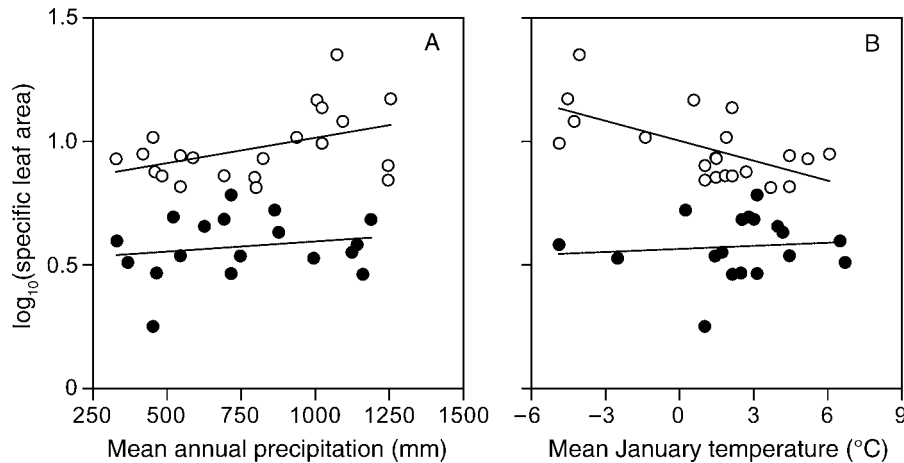

FIG. 2. Specific leaf area (SLA; originally measured in  $\text{mm}^2/\text{mg}$ ) vs. (A) mean precipitation, and (B) January temperatures within species ranges for species of *Cerastes* (solid circles) and *Euceanothus* (open circles).

### Community assembly

**Taxonomic co-occurrence.**—Of the 48 sites with two species, 38 had one from each of the two major clades (*Cerastes* and *Euceanothus*); this pattern was particularly striking in the Coast/Transverse (CT) chaparral sites (31 of 35 sites), but was not significant in the Sierra Nevada (SN) (Table 1). For both the full data set and the coastal partition, the elevated co-occurrence of species from different clades was highly significant, relative to the null model that maintained both site diversity and species occurrence ( $P \leq 0.001$ ). The frequent co-occurrence of taxa from the two clades has long been noted in the literature, but not previously quantified and tested relative to a null model.

**Trait disparity.**—Across all sites, the mean difference in  $\log_{10}(\text{SLA})$  between co-occurring species was 0.32 units, and as predicted this value was significantly greater than the null expectation ( $P < 0.04$ ; Table 2). In contrast, differences between climate niche parameters of co-occurring species were much smaller than expected ( $P \leq 0.001$  in both cases; Table 2). When the data are partitioned geographically, the within-site disparity in SLA was still significantly greater in CT, but disparity in SN was less than expected. Disparity in climate niche parameters is significantly lower than the null, as predicted, in both areas (Table 2). The among-site standard deviation in trait means was significantly greater than expected for climate niche traits, as predicted, in the entire data set and both geographic partitions. For SLA, it was significantly lower than expected in CT, but the pattern was reversed in SN (Table 2).

Collectively, these analyses indicate that in Coast and Transverse range chaparral, co-occurring *Ceanothus* species exhibit greater disparity in SLA than expected under a null model of community assembly. In contrast, in the Sierra Nevada it appears that SLA varies among sites, while within-site disparity is low,

perhaps due to distribution of evergreen vs. deciduous (low- vs. high-SLA) species along elevational gradients. As expected, climate niche parameters are always similar among co-occurring species and significantly different among sites.

### Divergence order test analysis

These results support the selection of SLA and realized climate niche parameters as traits reflecting local ( $\alpha$ ) vs. regional ( $\beta$ ) differentiation, respectively. The patterns are stronger in the Coast and Transverse ranges, and if there were a monophyletic group in *Ceanothus* restricted to these communities we would limit our analyses to this group. However, the evolutionary radiation into the two major clades, and subsequently within clades, encompasses both geographic areas (and beyond). We feel it is important to

TABLE 1. Relative frequency of local co-occurrence patterns for *Ceanothus*, in terms of the number of species from each major subgroup (CT = Coast and Transverse ranges; SN = Sierra Nevada).

Community pattern		No. communities		
<i>Cerastes</i>	<i>Euceanothus</i>	Total ( $P \leq 0.001$ )	CT ( $P \leq 0.001$ )	SN (NS)
0	2	7	2	5
1	1	38	31	7
2	0	3	2	1
0	3	2	0	2
1	2	1	0	1
2	1	0	0	0
3	0	0	0	0

*Notes:* Example of how to read Table 1: The first row indicates that a total of seven communities were recorded (two in CT and five in SN) with two co-occurring *Euceanothus* species and no *Cerastes*.  $P$  values indicate the probability of obtaining the observed number of sites occupied by species from the two subgroups, relative to a null model of community assembly (see text).

TABLE 2. Mean trait disparity among co-occurring species, and standard deviation of trait means among sites.

Trait	Mean disparity			SD of site means				
	Prediction	All ( $N = 51$ )	CT ( $N = 35$ )	SN ( $N = 16$ )	Prediction	All ( $N = 51$ )	CT ( $N = 35$ )	SN ( $N = 16$ )
Specific leaf area ( $\text{mm}^2/\text{mg}$ , log)								
Observed mean	>	0.32	0.35	0.25	<	0.158	0.093	0.170
Expected mean (SD)		0.29 (0.018)	0.28 (0.021)	0.28 (0.016)		0.17 (0.012)	0.15 (0.013)	0.14 (0.014)
$P$		<0.04	$\leq 0.001$	NS		NS	$\leq 0.001$	NS
Annual precipitation (mm)								
Observed mean	<	117	123	103	>	217	159	83
Expected mean (SD)		280 (25.2)	187 (17.3)	121 (8.7)		155 (12.1)	124 (10.5)	67 (8.22)
$P$		$\leq 0.001$	$\leq 0.002$	<0.03		$\leq 0.001$	$\leq 0.002$	<0.02
January minimum temperature ( $^{\circ}\text{C}$ )								
Observed mean	<	1.25	0.92	1.95	>	2.001	0.985	1.571
Expected mean (SD)		2.53 (0.19)	1.24 (0.093)	2.49 (0.21)		1.50 (0.11)	0.81 (0.065)	1.23 (0.14)
$P$		$\leq 0.001$	$\leq 0.002$	< 0.02		$\leq 0.001$	< 0.01	<0.02

Notes: Observed values are compared to expectations based on a null model of community assembly. Analyses were conducted for all sites, and for Coast and Transverse ranges (CT) and Sierra Nevada (SN) sites separately. Prior predictions regarding the direction of the difference between observed and expected values are listed, and all significance tests are one-tailed.

conduct evolutionary analyses on all available data for the entire group.

The three traits considered here generally fit the Brownian motion model underlying the use of ANCML for ancestral states. For all three traits, inspection of normal probability plots for the absolute value of standardized contrasts indicated a close fit to a truncated normal distribution. For SLA and January temperatures, correlations of standardized contrasts and their standard deviation (i.e., the square root of the subtending branch lengths) were not significant. For precipitation, the correlation was significantly negative across all trees, reflecting larger than expected divergences across rapid speciation events, and a small divergence across the long branches between *Cerastes* and *Eucaeanthus*. This pattern will lead to a relatively high Brownian motion rate parameter, to accommodate these rapid divergences, and will thus inflate the confidence intervals around the ancestral estimates for precipitation, making the DOT more conservative. Across most of the 100 trees, rates of trait evolution were homogeneous between *Cerastes* and *Eucaeanthus*; in 3 and 24 trees, rates of SLA and January temperature evolution, respectively, were significantly higher in *Eucaeanthus* ( $0.04 < P < 0.05$ ).

Fig. 3 illustrates trait divergences on a randomly selected tree from the analysis. The largest contrast for SLA was located at the basal node between *Cerastes* and *Eucaeanthus* (Fig. 3). The weighted divergence age for SLA, averaged across the 100 alternative phylogenies, was  $6.5 \times 10^{-3}$  branch length units (Table 3). For the climate parameters, the basal contrasts were much smaller, and larger divergences were noted within each of the two major clades (Fig. 3). The weighted divergence ages were  $4.30 \times 10^{-3}$  and  $4.24 \times 10^{-3}$  for January temperatures and precipitation, respectively.

For all 100 alternative phylogenies, weighted divergence ages were older for SLA than for both climate parameters, and the DOT was significant in 94 of 100 trees for the SLA vs. January temperature difference, and for 92 out of 100 trees for SLA vs. precipitation.

#### DISCUSSION

This analysis of the radiation of *Ceanothus* demonstrates an initial shift in  $\alpha$  niche traits that subsequently promote (or at least facilitate) coexistence among related species. These traits were then conserved as the radiation progressed, and later speciation events were characterized primarily by divergence in climate envelopes, corresponding to geographic differentiation along latitudinal and elevational gradients. The result is that co-occurring *Ceanothus* species within local communities are more distantly related than expected by chance, relative to the group as a whole.

Similar patterns are evident in other clades that have been analyzed in a phylogenetic context. In the oaks (*Quercus*) of Florida, local communities tend to be phylogenetically overdispersed, often with one or two members each drawn from three distinct clades (red, white, and live oaks). Habitat preferences diverge repeatedly within each of these clades; deeper divergences between the clades involve traits, such as seed maturation time and wood density, which may promote coexistence through differential regeneration or pathogen tolerance, respectively (Cavender-Bares et al. 2004). In studies of *Phylloscopus* warblers in Kashmir, Richman and Price (1992, Richman 1996) argued that deep divergences in the group involved differentiation in feeding strategies, while more recent speciation events were related to macrohabitat distributions (coniferous vs. deciduous forests) (but see Forstmeier et al. [2001]). In the radiation of *Anolis* lizards, distinctive ecomorphs, which coexist by feeding in different parts of the canopy,

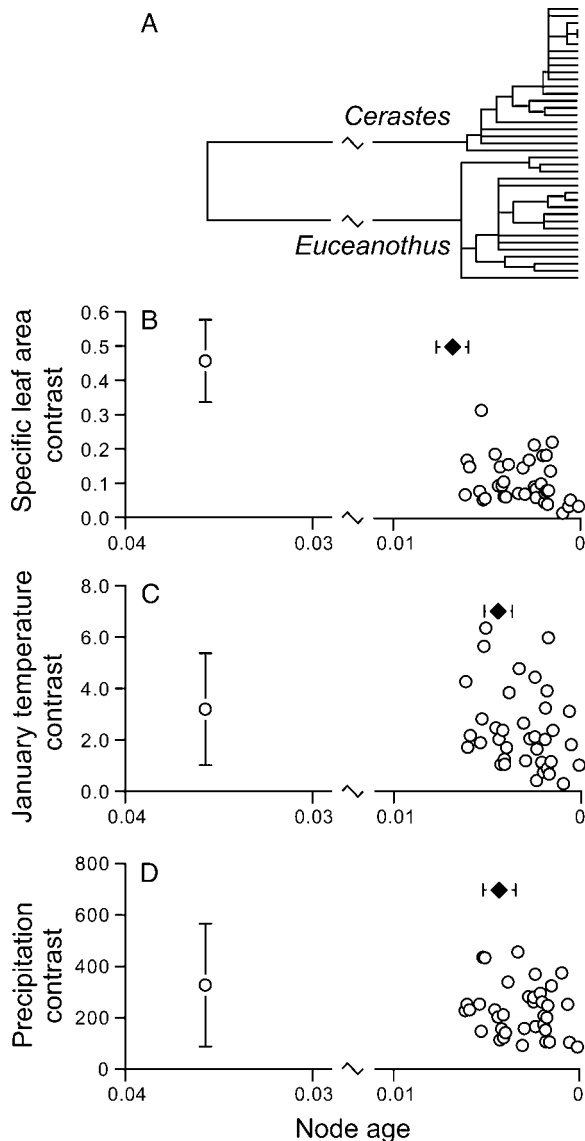

FIG. 3. Divergence order test (DOT) for *Ceanothus*, illustrated for one randomly chosen tree out of 100 equally parsimonious trees used for analysis. For all panels, ages along the x-axis are clock-calibrated molecular branch length units; the breaks in the axis indicate the long branches connecting the two recently diversifying clades. (A) *Ceanothus* phylogeny, based on reanalysis of internal transcribed spacer (ITS) sequence data from Hardig et al. (2000). Species names are omitted for clarity. (B–D) Open circles indicate the magnitude of unstandardized contrasts vs. node age for specific leaf area (SLA), January temperatures, and mean precipitation, respectively (see Table 3 for weighted mean ages). Standard errors of the contrasts (derived from the bootstrap procedure) are illustrated for the basal contrast only. The solid diamonds indicate weighted mean divergence age for each trait ( $\pm$ SE) based on 200 bootstrap randomizations of the contrasts (vertical position of this point is arbitrary).

have evolved independently on multiple islands (Losos et al. 1998, Knouft et al. 2006). On the larger islands, however, there has been continued speciation involving diversification of macrohabitats within ecomorph

groups (Glor et al. 2003). In our terminology, the earlier divergence events in each of these cases involve shifts in the  $\alpha$  niche, whereas  $\beta$  niche traits continue to diverge later in the radiation. Streebman and Danley (2003) include the anoles as one of the case studies in their review, considering the diversification of ecomorphs as an example of the first stage of radiation, involving microhabitat divergence. This is consistent with our interpretation of ecomorphs as diversification of the  $\alpha$  niche, although our terminology is different.

These case studies provide a striking contrast to Diamond's (1986) habitat-first model, which proposed that the first stage of speciation and adaptive radiation involved allopatric divergence along habitat gradients. These contrasting interpretations reflect differences in the interpretation of fast- vs. slow-evolving traits, and they highlight underlying philosophical differences in the interpretation of comparative data.

It is well known that phylogenetic inference works best for slowly evolving traits (Felsenstein 1988). Rapid evolution erodes the signal of early events on a phylogeny, due to reversals on the same or adjacent branches and convergence among the terminal states (strictly speaking, this is only true for traits with a finite number or range of states; Donoghue and Ree 2000, Ackery and Nyffeler 2004). For this reason, independent contrasts will generally provide an extremely poor estimate of the timing of divergence for rapidly evolving traits, as it will appear that there was little divergence in deeper nodes (e.g., Fig. 1). The high level of uncertainty in ML ancestral state reconstructions reflects this problem for rapidly evolving traits (Schluter et al. 1997, Cunningham et al. 1998) and led us to adopt the bootstrap method proposed here. In this situation, if the most recent speciation events in an adaptive radiation involve divergence in macrohabitat or habitat-related traits, it is parsimonious to assume that deeper events also involved such divergences (T. Price, *personal communication*), though evidence of this will not be available from phylogenetic analysis.

In contrast, for slowly evolving traits phylogenetic methods are quite powerful, leading to a different interpretation of the comparative data. For this case, as in the contrasting SLA values in *Ceanothus*, or divergent ecomorphs in *Anolis*, the greatest trait differences will generally be observed among distantly related species. The conservatism of these traits in diverse clades within each group strongly argues that the underlying divergences occurred during the initial speciation events early in the overall radiation. The view that  $\alpha$  niche divergence occurs late in the course of species differentiation, because these traits tend to differ between distantly related species, is not compatible with comparative phylogenetic analysis.

Taken together, these views lead to a possible synthesis of contrasting interpretations. In the cases discussed here, adaptive radiation may have proceeded by " $\alpha$  niche early" and " $\beta$  niche throughout." In other words, habitat divergence can occur frequently at all

TABLE 3. Results of the divergence order test (DOT) for relative divergence times of specific leaf area (SLA) and climate niche parameters in *Ceanothus*.

Trait	Mean age (SE)	<i>D</i> (SE)	No. nonzero
SLA	0.00654 (0.00083)	...	...
January temperature	0.00430 (0.00071)	0.00225 (0.00108)	94
Precipitation	0.00424 (0.00083)	0.00230 (0.00117)	92

*Notes:* Mean age is the average, over 100 alternative trees, of the weighted divergence times (*W*) for each trait. For each tree, *W* is derived by bootstrapping the ancestral states from maximum likelihood distributions for ancestral states, with 200 replicates; *D* is the mean difference in age of each climate parameter vs. SLA, over the 100 alternative trees; no. nonzero is the number of trees (out of 100) in which *D* was significantly different from zero, based on a one-tailed test of the hypothesis that mean age for SLA was older.

depths in the tree, although it can only be reconstructed with confidence in recent speciation events. Habitat differences clearly can play an important role in allopatric speciation, though it is important to note that allopatric populations might also occupy similar environments in different geographic areas (Peterson et al. 1999, Wiens 2004). In some cases, speciation also involves a shift in  $\alpha$  niche traits related to resource partitioning in local communities, but these events are apparently less frequent. Divergence in  $\alpha$  niche traits might be due to incidental divergence under conditions that favor different traits (e.g., island vs. mainland populations), or divergence by character displacement in sympatry due to direct competitive interactions between the incipient species (Schluter 2000, Levin 2004).

If correct, the “ $\alpha$  early,  $\beta$  throughout” model presents two unresolved questions about the evolution of  $\alpha$  niche traits. First, why should these traits exhibit evolutionary transitions early on in adaptive radiations? (At the time of this initial divergence, the adaptive radiation is still an unrealized future of the clade.) And second, why do  $\alpha$  niche traits often exhibit phylogenetic conservatism during subsequent diversification. With regard to the first question, it is tempting to identify divergence in  $\alpha$  niche traits as key innovations, or invasions of a novel adaptive zone (*sensu* Simpson 1953), contributing to the subsequent radiation. For example, in the case of *Ceanothus* we have strong evidence that California chaparral communities are capable of supporting at least one sprouting and one nonsprouting *Ceanothus* species. Thus, when this trait diverged early in the evolution of *Ceanothus* (the direction of evolution between ancestral and derived states is unknown), the two descendent subclades were both able to diversify in parallel across a broad gradient of climatic conditions. While such scenarios are plausible, and may be correct, it is difficult to conduct rigorous analyses of diversification hypotheses in terms of the timing of phenotypic innovation and hypothesized shifts in speciation rates (Sanderson and Donoghue 1994, Hodges 1995).

The second question addresses the important topic of niche conservatism: What are the mechanisms promoting evolutionary stasis in ecological traits through speciation and diversification of a clade? Recent theoretical analyses support the view that contrasting selection pressures in heterogeneous environments, combined with gene flow, interspecific competition, and/or habitat selection, can

generate stabilizing selection effects that lead to evolutionary stasis in niche parameters (Holt 1987, 2003, Kirkpatrick and Barton 1997, Case and Taper 2000). Empirical studies of these predictions are needed. The roles of niche conservatism in speciation, the evolution of regional biota and the assembly of communities has recently received increased attention (Webb et al. 2002, Ackerly 2003, Wiens 2004), and each of these offers a counterpoint to the emphasis on ecological divergence as a key component of evolutionary radiations.

The conclusion that  $\alpha$  niche traits evolve relatively slowly during an adaptive radiation contrasts with the views of Silvertown et al. (2006a, b) on niche evolution. They argue, based on several lines of evidence, that the  $\alpha$  niche evolves rapidly, and as a corollary local communities usually show little phylogenetic signal in their species composition. This conclusion is supported by their analysis of the phylogenetic structure of English meadow communities (Silvertown et al. 2001, 2006a, b) and by comparison of niche overlap between congeneric and noncongeneric species within local communities. The apparent conflict between their analyses and our conclusions is most likely due to the different scales of analysis and sampling of taxa. The species of the English meadow communities are widely dispersed across the angiosperm phylogeny. When the phylogeny is pruned for analysis of niche distributions, the closest relatives remaining on the tree are rarely if ever immediate sibling species. As a result, even the most recent “events” represented on such a phylogeny are relatively old compared to our analysis of adaptive radiations. Thus, Silvertown et al.’s (2006a) conclusions and our analyses may be entirely compatible, but focused on different scales of analysis.

#### CONCLUSIONS

The divergence order test (DOT) introduced here provides a quantitative approach to test hypotheses about the relative sequence of divergence for continuous traits. Considering the potential pitfalls in comparative analysis of rapidly evolving traits, the bootstrap method incorporating the uncertainty of ancestral state reconstructions provides a conservative approach for significance testing. Our application of the DOT to *Ceanothus*, and interpretation of other cases in the literature, leads to the conclusion that  $\alpha$  niche traits often diverge early in the course of adaptive radiations. The  $\beta$  niche traits,

which are related to macrohabitat distributions, might evolve rapidly throughout the radiation, although the signal of early divergences is erased by the high rates of evolution. Further application of the DOT, or improved tests addressing these questions, will provide an important step towards synthesis of niche evolution and adaptive radiation.

## ACKNOWLEDGMENTS

D. D. Ackerly thanks C. O. Webb and J. B. Losos for the invitation to contribute this paper to the ESA symposium and this special issue on Phylogenetics and Community Ecology. The authors thank D. Schluter and T. Price for valuable discussions and comments that improved the manuscript. This research was supported by National Science Foundation grants 0212873 to C. O. Webb, M. J. Donoghue, and D. D. Ackerly and 0078301 to D. D. Ackerly.

## LITERATURE CITED

- Ackerly, D. D. 2000. Taxon sampling, correlated evolution and independent contrasts. *Evolution* **54**:1480–1492.
- Ackerly, D. D. 2003. Community assembly, niche conservatism and adaptive evolution in changing environments. *International Journal of Plant Sciences* **164**:S165–S184.
- Ackerly, D. D. 2004a. Adaptation, niche conservatism and convergence: comparative studies of leaf evolution in the California chaparral. *American Naturalist* **163**:654–671.
- Ackerly, D. D. 2004b. Functional strategies of chaparral shrubs in relation to seasonal water deficit and disturbance. *Ecological Monographs* **75**:25–44.
- Ackerly, D. D., and R. Nyffeler. 2004. Evolutionary diversification of continuous traits: phylogenetic tests and application to seed size in the California flora. *Evolutionary Ecology* **18**:249–272.
- Axelrod, D. I. 1956. Mio-Pliocene floras from west-central Nevada. University of California Publications in Geological Sciences **33**:1–316.
- Case, T. J., and M. L. Taper. 2000. Interspecific competition, environmental gradients, gene flow, and the coevolution of species' borders. *American Naturalist* **155**:583–605.
- Cavender-Bares, J., D. D. Ackerly, D. Baum, and F. A. Bazzaz. 2004. Phylogenetic repulsion in the assembly of Floridean oak communities. *American Naturalist* **163**:823–843.
- Chaney, R. W. 1927. Geology and palaeontology of the Crooked River Basin with special reference to the Bridge Creek Flora. Carnegie Institution of Washington Publication **346**:45–138.
- Chase, J., and M. Leibold. 2003. Ecological niches: linking classical and contemporary approaches. University of Chicago Press, Chicago, Illinois, USA.
- Chesson, P. L. 2000. Mechanisms of maintenance of species diversity. *Annual Review of Ecology and Systematics* **31**:343–367.
- Cunningham, C. W., K. Omland, and T. H. Oakley. 1998. Reconstructing ancestral character states: a critical reappraisal. *Trends in Ecology and Evolution* **13**:361–366.
- Darwin, C. 1859. *On the origin of species*. Murray, London, UK.
- Davis, S. D., F. W. Ewers, J. Wood, J. J. Reeves, and K. J. Kolb. 1999. Differential susceptibility to xylem cavitation among three pairs of *Ceanothus* species in the Transverse mountain ranges of Southern California. *Ecoscience* **6**:180–186.
- Diamond, J. M. 1986. Evolution of ecological segregation in the New Guinea montane avifauna. Pages 98–125 in J. M. Diamond and T. J. Case, editors. *Community ecology*. Harper and Row, Cambridge, Massachusetts, USA.
- Diaz-Uriarte, R., and T. Garland, Jr. 1996. Testing hypotheses of correlated evolution using phylogenetically independent contrasts: sensitivity to deviations from Brownian motion. *Systematic Biology* **45**:27–47.
- Donoghue, M. J., and R. Ree. 2000. Homoplasy and developmental constraint: a model and example from plants. *American Zoologist* **40**:759–769.
- Elton, C. 1946. Competition and the structure of ecological communities. *Journal of Animal Ecology* **15**:54–68.
- Felsenstein, J. 1985. Phylogenies and the comparative method. *American Naturalist* **125**:1–15.
- Felsenstein, J. 1988. Phylogenies and quantitative characters. *Annual Review of Ecology and Systematics* **19**:445–471.
- Forstmeier, W., O. Bourski, and B. Leisler. 2001. Habitat choice in *Phylloscopus* warblers: the role of morphology, phylogeny and competition. *Oecologia* **128**:566–576.
- Garland, T., Jr. 1992. Rate tests for phenotypic evolution using phylogenetically independent contrasts. *American Naturalist* **140**:509–519.
- Garland, T., Jr., P. H. Harvey, and A. R. Ives. 1992. Procedures for the analysis of comparative data using phylogenetically independent contrasts. *Systematic Biology* **41**:18–32.
- Glor, R. E., J. J. Kolbe, R. Powell, A. Larson, and J. B. Losos. 2003. Phylogenetic analysis of ecological and morphological diversification in Hispaniolan trunk-ground anoles (*Anolis cybotes* group). *Evolution* **57**:2383–2397.
- Gotelli, N. J., and G. Entsminger. 2001. Swap and fill algorithms in null model analysis: rethinking the knight's tour. *Oecologia* **129**:281–291.
- Gotelli, N., and G. Graves. 1996. *Null models in ecology*. Smithsonian Institution Press, Washington D.C., USA.
- Graham, A. 1999. *Late Cretaceous and Cenozoic history of North American vegetation*. Oxford University Press, New York, New York, USA.
- Graham, C. H., S. R. Ron, J. C. Santos, C. J. Schneider, and C. Moritz. 2004. Integrating phylogenetics and environmental niche models to explore speciation mechanisms in dendrobatid frogs. *Evolution* **58**:1781–1793.
- Hacke, U., J. Sperry, W. Pockman, S. Davis, and K. McCulloch. 2001. Trends in wood density and structure are linked to prevention of xylem implosion by negative pressure. *Oecologia* **126**:457–461.
- Hardig, T. M., P. S. Soltis, and D. E. Soltis. 2000. Diversification of the North American shrub genus *Ceanothus* (Rhamnaceae): conflicting phylogenies from nuclear ribosomal DNA and chloroplast DNA. *American Journal of Botany* **87**:108–123.
- Harvey, P. H., and M. Pagel. 1991. *The comparative method in evolutionary biology*. Oxford University Press, Oxford, UK.
- Hellmers, H., J. S. Horton, G. Juhren, and J. O'Keefe. 1955. Root systems of some chaparral shrubs in Southern California. *Ecology* **36**:667–678.
- Hickman, J. C. 1993. *The Jepson manual: higher plants of California*. University of California Press, Berkeley, California, USA.
- Hodges, S. 1995. Spurring plant diversification: Are floral nectar spurs a key innovation? *Proceedings of the Royal Society (London) B* **262**:343–348.
- Holt, R. D. 1987. Population dynamics and evolutionary processes: the manifold roles of habitat selection. *Evolutionary Ecology* **1**:331–347.
- Holt, R. D. 2003. On the evolutionary ecology of species' ranges. *Evolutionary Ecology Research* **5**:159–178.
- Hubbell, S. P. 2001. *The unified neutral theory of biodiversity and biogeography*. Princeton University Press, Princeton, New Jersey, USA.
- Jeong, S.-C., A. Liston, and D. D. Myrold. 1997. Molecular phylogeny of the genus *Ceanothus* (Rhamnaceae) using *rbcL* and *ndhF* sequences. *Theoretical and Applied Genetics* **94**:852–857.
- Keeley, J. E. 1977. Fire-dependent reproductive strategies in *Arctostaphylos* and *Ceanothus*. Pages 391–396 in H. A. Mooney and C. E. Conrad, editors. *Proceedings of the Symposium on Environmental Consequences of Fire and Fuel Management in Mediterranean Ecosystems*. USDA Forest Service General Technical Report WO-3, Washington, D.C., USA.
- Keeley, J. E., and P. H. Zedler. 1978. Reproduction of chaparral shrubs after fire: a comparison of sprouting and seeding strategies. *American Midland Naturalist* **99**:142–161.
- Kirkpatrick, M., and N. H. Barton. 1997. Evolution of a species' range. *American Naturalist* **150**:1–23.

- Knight, C., and D. D. Ackerly. 2001. Correlated evolution of chloroplast heat shock protein expression in closely related plant species. *American Journal of Botany* **88**:411–418.
- Knouft, J. H., J. B. Losos, R. E. Glor, and J. J. Kolbe. 2006. Phylogenetic analysis of the evolution of the niche in lizards of the *Anolis sagrei* group. *Ecology* **87**:S29–S38.
- Levin, D. A. 2004. Ecological speciation: crossing the divide. *Systematic Botany* **29**:807–816.
- Losos, J., T. Jackman, A. Larson, K. de Queiroz, and L. Rodriguez-Schettino. 1998. Contingency and determinism in replicated adaptive radiations of island lizards. *Science* **279**:2115–2118.
- McMinn, H. 1942. *Ceanothus*. Volume II. A systematic study of the genus *Ceanothus*. Santa Barbara Botanical Gardens, Santa Barbara, California, USA.
- Nicholson, P. 1993. Ecological and historical biogeography of *Ceanothus* (Rhamnaceae) in the Transverse Ranges of Southern California. Dissertation. University of California, Los Angeles, California, USA.
- Oakley, T. H., and C. W. Cunningham. 2000. Independent contrasts succeed where ancestral reconstruction fails in a known bacteriophage phylogeny. *Evolution* **54**:397–405.
- O'Meara, B. C., C. Ané, M. J. Sanderson, and P. C. Wainwright. *In press*. Testing for different rates of evolution using likelihood. *Evolution*.
- Peterson, A. T., J. Soberon, and V. Sanchez-Cordero. 1999. Conservatism of ecological niches in evolutionary time. *Science* **285**:1265–1267.
- Pickett, S., and F. Bazzaz. 1978. Organization of an assemblage of early successional species on a soil moisture gradient. *Ecology* **59**:1248–1255.
- R Development Core Team. 2004. R: a language and environment for statistical computing. R Foundation for Statistical Computing, Vienna, Austria.
- Reich, P. B., M. B. Walters, and D. S. Ellsworth. 1997. From tropics to tundra: global convergence in plant functioning. *Proceedings of the National Academy of Sciences (USA)* **94**:13730–13734.
- Richman, A. D. 1996. Ecological diversification and community structure in the Old World leaf warblers (genus *Phylloscopus*): a phylogenetic perspective. *Evolution* **50**:2461–2470.
- Richman, A., and T. Price. 1992. Evolution of ecological differences in Old World warblers. *Nature* **355**:817–821.
- Sanderson, M. J. 2002. Estimating absolute rates of molecular evolution and divergence times: a penalized likelihood approach. *Molecular Biology and Evolution*. **19**:101–109.
- Sanderson, M. J. 2003. r8s: Inferring absolute rates of molecular evolution and divergence times in the absence of a molecular clock. *Bioinformatics* **19**:301–302.
- Sanderson, M., and M. Donoghue. 1994. Shifts in diversification rate with the origin of angiosperms. *Science* **264**:1590–1593.
- Schluter, D. 2000. The ecology of adaptive radiations. Oxford University Press, Oxford, UK.
- Schluter, D., T. Price, A. Mooers, and D. Ludwig. 1997. Likelihood of ancestor states in adaptive radiation. *Evolution* **51**:1699–1711.
- Schwilk, D. W., and D. D. Ackerly. 2005. Is there a cost to resprouting? Seedling growth rate and drought tolerance in sprouting and nonsprouting *Ceanothus* (Rhamnaceae). *American Journal of Botany* **92**:404–410.
- Silvertown, J., M. Dodd, and D. Gowing. 2001. Phylogeny and the niche structure of meadow plant communities. *Journal of Ecology* **89**:428–435.
- Silvertown, J., M. Dodd, D. Gowing, C. Lawson, and K. McConway. 2006a. Phylogeny and the hierarchical organization of plant diversity. *Ecology* **87**:S39–S49.
- Silvertown, J., K. McConway, D. Gowing, M. Dodd, M. F. Fay, J. A. Joseph, and K. Dolphin. 2006b. Absence of phylogenetic signal in the niche structure of meadow plant communities. *Proceedings of the Royal Society (London) B* **273**:39–44.
- Simpson, G. G. 1953. The major features of evolution. Columbia University Press, New York, New York, USA.
- Streelman, J. T., and P. D. Danley. 2003. The stages of vertebrate evolutionary radiation. *Trends in Ecology and Evolution* **18**:126–131.
- Swofford, D. L. 2002. PAUP\*: phylogenetic analysis using parsimony. Version 4.10b. Sinauer, Sunderland, Massachusetts, USA.
- Webb, C. O., D. D. Ackerly, and S. Kembel. 2004. Phylocom: software for the analysis of community phylogenetic structure and character evolution. (<http://www.phylodiversity.net/phylocom>)
- Webb, C. O., D. D. Ackerly, M. McPeck, and M. J. Donoghue. 2002. Phylogenies and community ecology. *Annual Review of Ecology and Systematics* **33**:475–505.
- Wells, P. V. 1969. The relation between mode of reproduction and extent of speciation in woody genera of the California chaparral. *Evolution* **23**:264–267.
- Whittaker, R. 1975. *Communities and ecosystems*. Macmillan, New York, New York, USA.
- Wiens, J. J. 2004. Speciation and ecology revisited: phylogenetic niche conservatism and the origin of species. *Evolution* **58**:193–197.
- Williams, C. B. 1964. *Patterns in the balance of nature*. Academic Press, New York, New York, USA.
- Wright, I. J., et al. 2004. The leaf economic spectrum worldwide. *Nature* **428**:821–827.

#### APPENDIX A

Discussion of alternative null models (*Ecological Archives* E087-110-A1).

#### APPENDIX B

*Ceanothus* occurrence matrix (*Ecological Archives* E087-110-A2).

#### APPENDIX C

*Ceanothus* trait matrix (*Ecological Archives* E087-110-A3).

#### SUPPLEMENT

Source code for DOT (*Ecological Archives* E087-110-S1).